

> Manual ICON EXH



Breezair[®]

EXH EVAPORATIVE
COOLER

ICON
SERIES

INSTALLATION
MANUAL

> Manual ICON EXH

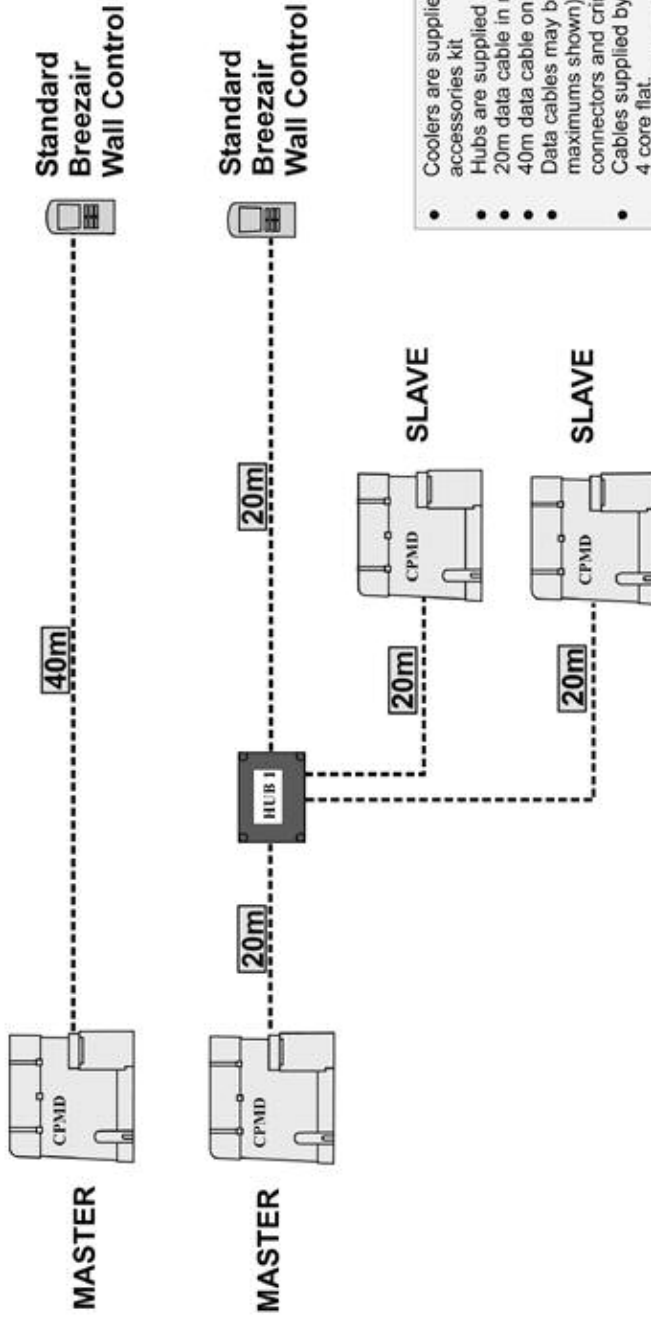

- Coolers are supplied with 20m data cable in accessories kit
- Hubs are supplied with 20m data cable in kit.
- 20m data cable in re-sealable bag available
- 40m data cable on reel available
- Data cables may be shortened or lengthened (to maximums shown) using ONLY correct RJ connectors and crimping tools
- Cables supplied by Breezair are 26AWG, 7/013, 4 core flat.
- ALWAYS route cables at least 300mm away from regular power cables and high power machines. Cross over power cables at right angles.
- Where maximum data cable and sensor cable lengths are exceeded, or cables are not routed in accordance with our recommendations Seeley technical support is not available and the product warranty may be voided.

Breezair Control System
Cable Lengths
Standard Wall Control

824130-A 0703

> Manual ICON EXH

Breeza® Quick install guide **1**

Step 1  **Page 2**

1. Read & understand the safety section.

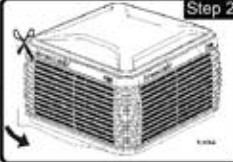
Step 2  **Page 3**

1. Unwrap the Cooler.
2. Remove from pallet.

Step 3  **Page 3**

1. Remove pads.

Step 4  **Page 3**

1. Check cooler location.
2. Be aware of regulations.
3. Discuss with customer.

Step 5  **Page 3**

1. Cut cable hole in duct.
2. Position, level and secure the duct.
3. Flash the duct.

Step 6  **Page 4**

1. Transport the cooler to the roof.
2. Always handle the cooler using 2 people.

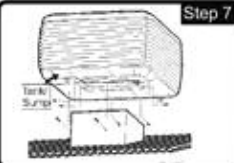
Step 7  **Page 4**

1. Unhook the power cable.
2. Secure the cooler to duct.
3. Run the power & control cable through the duct.

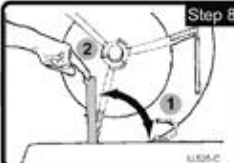
Step 8  **Page 5**

1. Set the position of the transport latch.
2. Check operation of the weatherdamper.

Step 9  **Page 5**

1. Read and adhere to the local electrical and plumbing rules and regulations.

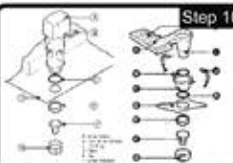
Step 10  **Page 6**

1. Fit the drain valve (or bleed tray). Connect discharge system.
2. Plug drain valve power cable into control box.

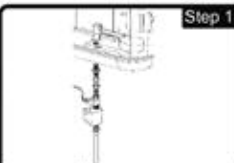
Step 11  **Page 6**

1. Fit solenoid and connect cable.
2. Connect water supply.
3. Install drain pipe.

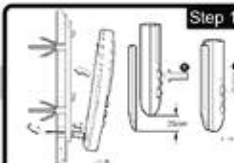
Step 12  **Page 7**

1. Select the best position for the wall/remote control.
2. Run wall control cable, or fit receiver and run cable.
3. Mount wall/remote control tracks.

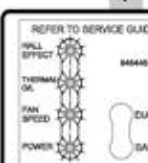
Step 13  **Page 9**

1. Test the cooler with the wall control at the unit.
2. Check the diagnostics of the electronics module.

Step 14  **Page 10**

1. Check installation for safety then power up cooler.
2. Check correct connection of cables.

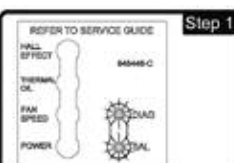
Step 15  **Page 10**

1. Test operation of cooler.
2. Check the operation of the diagnostic LEDs on the control box.

Step 16  **Page 11**

1. Set the water level.
2. Set the bleed rate (Homemaker only).

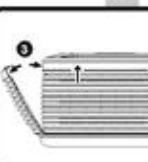
Step 17  **Page 11**

1. Refit the pads.
2. Test run the cooler.
3. Check water distribution to all pads.

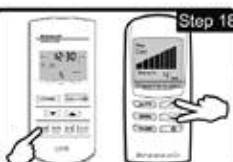
Step 18  **Page 12**

1. If the cooler has a drain valve fitted, initiate a drain of the tank.
2. Check for leaks.

Step 19  **Page 12**

1. Clean up the site.

Step 20  **Page 12**

1. Show the customer how to operate their new cooler.
2. Give the customer their owners manual.

> Manual ICON EXH

Breezair®

Safety

2

EMPLOYER AND EMPLOYEE RESPONSIBILITIES

The installation and maintenance of evaporative air conditioning units at height has the potential to create Occupational Health and Safety issues for those involved. Installers are advised to ensure they are familiar with the relevant State and Federal legislation, such as Acts, Regulations, approved Codes of Practice and Australian Standards, which offer practical guidance on these health and safety issues. Compliance with these regulations will require appropriate work practices, equipment, training and qualifications of workers.

Seeley International provides the following information as a guide to contractors and employees to assist in minimising risk whilst working at height.

Installer and Maintenance Contractors

A risk assessment is an essential element that should be conducted before the commencement of work, to identify and eliminate the risk of falls or to minimise these risks by implementing control measures.

Risk Assessment

A risk assessment of all hazardous tasks is required under legislation.

There is no need for this to be a complicated process, it just is a matter of looking at the job to be done and considering what action(s) are necessary so the person doing the job does not injure themselves.

This should be considered in terms of:

- What are the chances of an incident happening?
- What could the possible consequence be?
- What can you do to reduce, or better still, completely get rid of the risk?

Some points to consider:

- What is the best and safest access to the roof and working areas?
- If a worker is alone, who knows they are there and if they get into difficulty, how can they summon help? (Call someone on the ground? Mobile phone? etc.)
- What condition is the roof in? Should the trusses, underside or surface be checked?
- Does the worker have appropriate foot wear? (Flat sole jogger type is advisable)
- Are all power cables / extension leads safe and appropriately rated?
- Are all ladders, tools and equipment suitable in good condition?
- Where ladders are to be used, is there a firm, stable base for them to stand on? Can they be tied or secured in some way at the top? Is the top of the ladder clear of electricity supply cables?
- Is there a roof anchor to attach a harness and lanyard to? If so, instruction should be issued for the use of an approved harness or only suitably trained people used.
- Are all tools and materials being used, prevented from slipping and falling onto a person at ground level? Is the area below the work area suitably protected to prevent persons walking in this area?
- Does the work schedule take into account weather conditions, allowing for work to be suspended in high winds, thunder storms/lightning or other types of weather giving wet, slippery surfaces?
- Is there an on-going safety check system of harnesses, ropes, ladders and access/lifting equipment and where they exist on roofs, anchor points before the commencement of work?
- Is there a system which prevents employees from working on roofs if they are unwell or under the influence of drugs or alcohol?
- Are there any special conditions to consider i.e. excessive roof pitch, limited ground area, fragile roof, electrical power lines?

OTHER IMPORTANT REQUIREMENTS

Never force parts to fit because all parts are designed to fit together easily without undue force.

Never drill any holes in the primary base surface or side walls of the bottom tank (reservoir) of the cooler.

Check the proposed cooler location, to ensure that it is structurally capable of supporting the weight of the cooler, or provide an adequate alternate load bearing structure.

ALWAYS route cables at least 300mm away from regular power cables and high power machines. Cross over power cables at right angles.

Where maximum data cable and sensor cable lengths are exceeded, or cables are not routed in accordance with our recommendations Seeley technical support is not available and the product warranty may be voided.

> Manual ICON EXH



Installing the EXH

3

UNPACKING THE COOLER

Cut and remove the shrink wrap from around the cooler. Using 2 people, carefully lift the cooler up and away from its pallet (Fig 1).

Removing Pad Frames

Firstly remove the corner clips, which are located above the top louvre and third louvre from the bottom on all corner joins. The clips will require a screw driver to aid removal.

Each frame is clipped into the cooler and is removed by use of a medium sized screwdriver. Insert the screwdriver into the small slots at the top of the frame and lever upwards until the clips disengage. The frame is now free to be lifted out of the cooler cabinet (Fig 2).

COOLER LOCATION

Check the proposed cooler location, to ensure that it is structurally capable of supporting the weight of the cooler, or provide an adequate alternate load bearing structure.

Always locate the cooler where it will receive a plentiful supply of fresh air. Not in a recess where it may be starved for air or where the air is polluted.

- Ensure the location is a minimum of: 3m from a solid fuel heater flue, 1.5m from a gas flue, 5m from a sewer vent and 600mm from a wall.
- In areas with poor signal strength, the cooler should be mounted away from a TV antenna (or the antenna moved away from the cooler) to ensure there is no possibility of interference with the TV reception.

Allow adequate access to and around the cooler for maintenance. Provision must be made for access to electricity, water supplies and drains. Note: Do you need to discuss the installation of items like safety anchor points with the customer?

The ideal location for the cooler is in a central position on the roof (away from sleeping areas and where people spend most of their time) so that the duct runs are of approximately the same length.

Carefully consider neighbouring residences and noise levels when locating the cooler, if necessary talk to the customer and the neighbour before carrying out the installation.

MOUNTING THE DROPPER

Cut the 50mm diameter cable exit hole in the dropper then fit and screw the cable grommet into position (Fig 4). Locate the hole so that the cables will not interfere with the fully opened weather damper.

Install the dropper and securely fix it to the roof structure on 3 sides (Fig 5). This may require the addition of some extra structural timber.

Ensure that the top of the dropper is level and square (use a spirit level). This procedure also helps level the lip of the tank.

Ensure dropper insulation is firmly held against the dropper and trim any long insulation retention studs in the path of the auto weatherdamper.

The dropper may now be flashed to the roof. Make sure there is no chance of any water entering the roofspace.

Important! The dropper must never sit directly on to any ceiling joists or beams, as there may be associated noise transfer, causing problems after installation, including possible ceiling damage.

In high wind areas or exposed areas (e.g. a cliff top or a flat treeless area) use 16 screws, minimum shank diameter 5.2 mm. In areas subject to cyclones, or where the cooler is located more than 8 m above the ground, seek advice from a structural engineer.

The installer must ensure the dropper is suitable, and is secured adequately for the wind conditions at the site. Should the cooler be an average of more than 200 mm from the roof timbers, or should the design wind velocity at the cooler exceed 43 m/s, then additional restraints may be required.

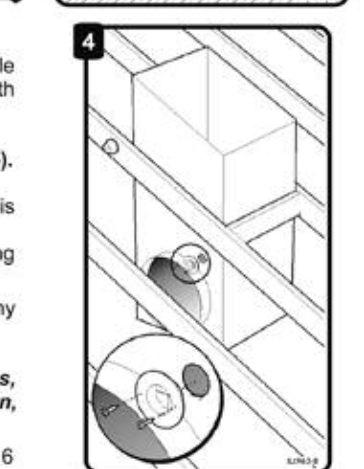
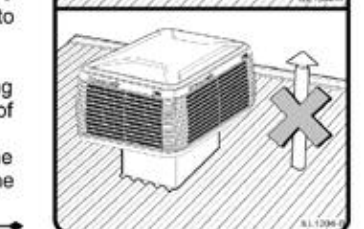
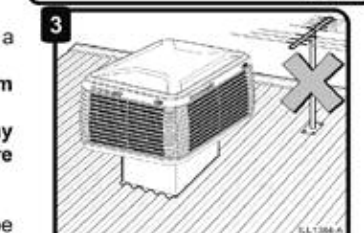
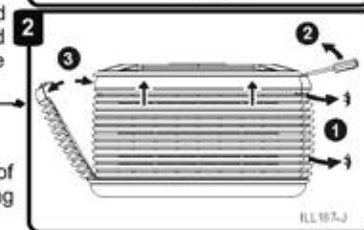
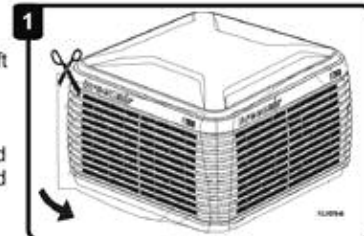

> Manual ICON EXH



Installing the EXH

4

MOUNTING THE COOLER

Before mounting the cooler on the duct, release the mains power cable from the hook as shown in figure 6a.

The tank sump is designed to be placed on the low (gutter) side of the installation.

Place the cooler as shown (Fig 6b). Check the weatherdamper moves without obstruction. Fix to the duct with eight (8) self tapping screws provided (2 screws per side).

There are ten screw locations identified by a "V" notch. If access to the "top" is prevented, use three screws on each side and two on the front.

Screw length must be limited to a maximum of 40mm to avoid interfering with the weather damper. After securing the cooler, check for free operation of the weather damper over its full travel. (See weather damper latch section - page 5).

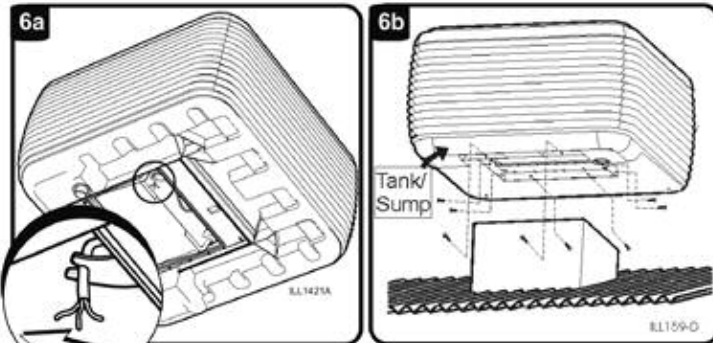

INSTALLING THE CABLES

Cut the cable tie holding the mains power cable inside the cooler. Feed the cable into the duct as shown in figure 7.

Feed the looped end of the low voltage wall control cable through the "wedge shaped" knockout provided and into the dropper (Fig 7A,B). Connect the other end (with ferrite suppression fitted) to the electronics module (Fig 8, item C).

Important! Ensure cables do not interfere with the weatherdamper and that it opens and closes properly.

Note!

1/ It is important to route both cables out through the dropper grommet **before** fitting the ductwork.

2/ The 4 pin plug on the remote receiver cable (the end without "receiver" sticker attached) is connected to the electronics module inside the cooler.

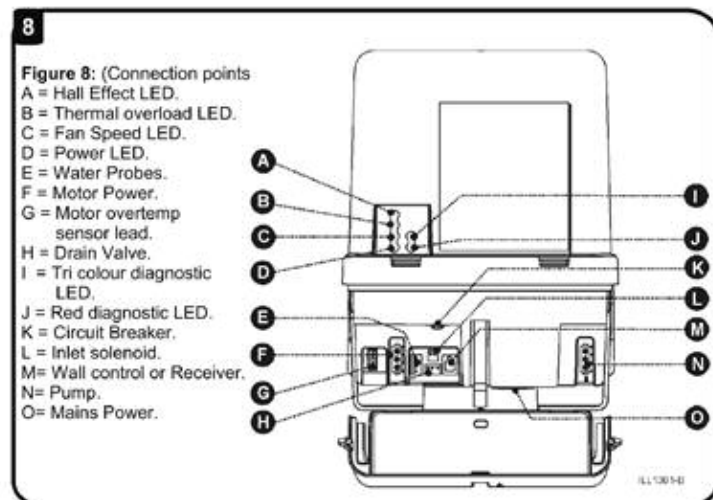
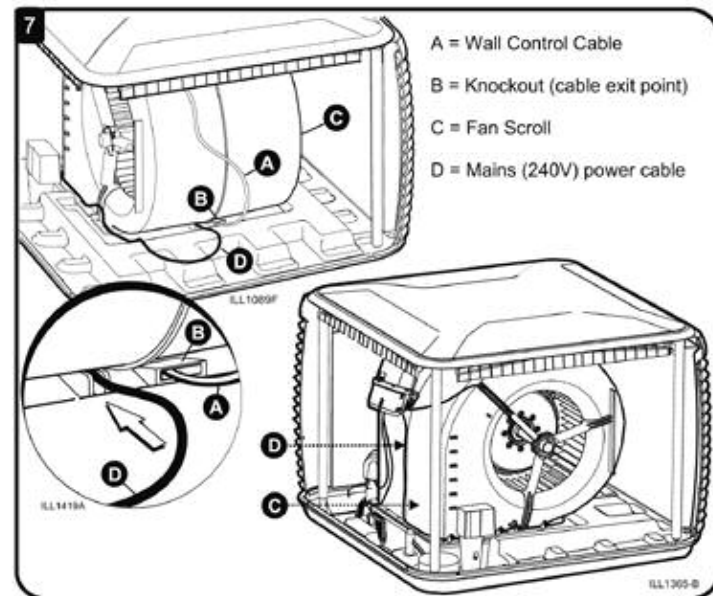

> Manual ICON EXH

Breezair®

Installing the EXH

5

WEATHERDAMPER AND LATCH

The weatherdamper latch performs two functions (Fig 10). In the locked position it acts as a transport latch preventing movement during transport. In the operating position it acts as a restrainer preventing gusts of wind from opening it.

Once the unit is installed on the roof squeeze the latch and rotate it clockwise to its operating position. Lift the latch and check by lifting the counter weight, that the weatherdamper flap is free to move. The counterweight should move freely through 90° (Fig 9).

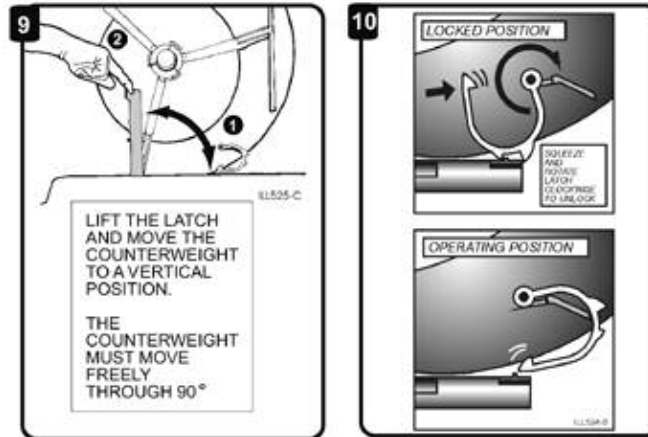

ELECTRICAL REQUIREMENTS

Installation of the Cooler must conform to local electrical rules, regulations and standards.

It is a requirement of Seeley International that all Coolers be wired with a dedicated circuit to the distribution board adhering to local and national wiring standards .

A 10A socket outlet within one metre of the dropper's cable exit hole is required.

Specification : 240V / 50Hz Single Phase

The electronics module is fitted with a 12A resettable circuit breaker. To reset the circuit breaker turn off the isolation switch, remove the electronics module and push the manual reset toggle switch located underneath the electronics module.

WATER REQUIREMENTS

Installation of the Cooler water supply must conform to local plumbing rules, regulations and standards.

The following specifications for water supply are required:

Water Connections : 1/2" BSP
Water Supply : 800 Kpa (115 psi) MAXIMUM

Important! If the water pressure exceeds this maximum specification then a pressure reducing valve is required and must be supplied and fitted by the installer.

Harmony & Horizon controls

For Coolers with the inlet solenoid valve fitted, the water connection is a 1/2" BSP compression fitting on the end of a flexible hose. This can fit directly onto the water pipe or be screwed directly onto the manual water shut-off valve. Always ensure that the water pipe connection does not place sideways strain onto the float valve.

Homemaker control

A permanent water supply is required to be connected to the float valve. The water connection point is located on the underside of the cooler.

The water connection fitting is a 1/2" BSP male adaptor suitable for a compression fitting. Do not fit the manual water shut-off valve directly onto the plastic nipple.

You must install a manual 1/4 turn ball type shut off valve (do not use a stop cock) in the water supply line adjacent to the cooler, subject to local plumbing regulations. This allows the water supply to be isolated whenever work needs to be done on the cooler.

In areas subject to freezing, the water line needs a drain down facility.

Important! Flush the water pipe to remove any swarf before final fitting. Swarf can lodge in the solenoid and float valve, preventing them from functioning correctly.

> Manual ICON EXH

Breezair®

Installing the EXH

6

INSTALLING THE DRAIN KIT / BLEED TRAY

The correct drain system must be used. Drain water from the bleed tray or drain valve must be carried away to a suitable discharge point on the building or property, in accordance with local regulations.

It is a requirement of Seeley International - Never drain the water directly on to the roof (This applies to all types of control/drain systems).

Harmony and Horizon

Assemble drain valve as shown (Fig 12).

Make sure that the o-ring is fitted before placing the drain valve into the hole. Screw the nut up tightly by hand underneath the Cooler. **Do not overtighten.** Now connect the cable to the electronics module (Fig 8, item F).

Homemaker

Fit the bleed tray as shown (Fig 11).

Screw the nut up tightly by hand underneath the cooler. **Do not overtighten.**

Note! Make sure the bleed tray is correctly oriented (the bleed tray must sit underneath the Chilcel pad when it is fitted) and that the o-rings are fitted before placing the threaded bush into the hole. The bleed rate is controlled by the number of plugs that are inserted into the tray. The more plugs inserted, the more water will bleed off.

Important! For Homemaker models, the water probes and inlet solenoid cable must be removed and discarded. The supplied shorting plug must be fitted to the electronics module (before the power is turned on), where the water probes were connected (Fig 13, item A).

Failure to fit the shorting plug will result in the pump not operating.

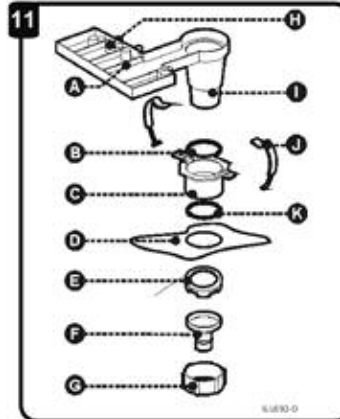

Figure 11 A = Ribs.
B = O - Ring.
C = Threaded Bush.
D = Tank (Reservoir).
E = Nut.
F = Drain Adaptor.
G = Lock nut.
H = Removable Plugs
I = Bleed Tray.
J = Spring Clip.
K = O- Ring.

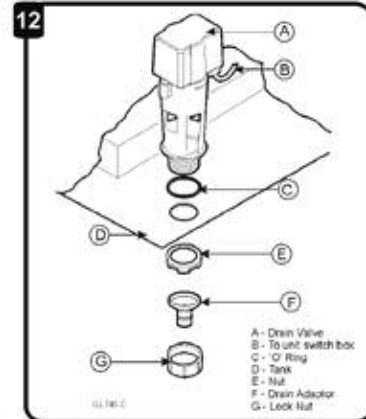

Figure 12: A = Drain Valve.
B = Power Lead (plugs into Control Box)
C = O- Ring.
D = Tank (Reservoir).
E = Nut.
F = Drain Adaptor.
G = Lock nut.

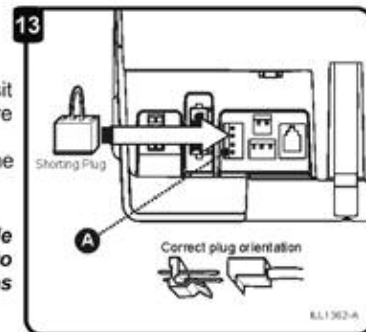

Figure 13: A = Remove water probes plug and fit shorting plug here (Homemaker only).

INSTALLING THE INLET SOLENOID (Harmony and Horizon only)

Fit the inlet solenoid under the tank as shown (Fig 14).

Note! Do not disconnect the flexible hose from the solenoid valve.

Insert the cable through the hole (behind the drain valve) and connect the plugs to the water solenoid valve. Make sure the cable is fitted to the groove underneath the tank, so that it does not get trapped by the solenoid cover when it is fitted. The electrical cable leads may be connected to the solenoid either way around.

Fitting the Solenoid Cover:

Once the Solenoid Valve and its cable have been fitted, place the cover over the assembly. Ensure that the cover does not touch the Solenoid. Also make sure the Solenoid Valve cable is retained in the groove in the Cooler tank. Then secure the cover at each end with the two screws supplied.

If freezing conditions can occur at any time, a drain down facility must be provided at the lowest point of the water supply pipe.

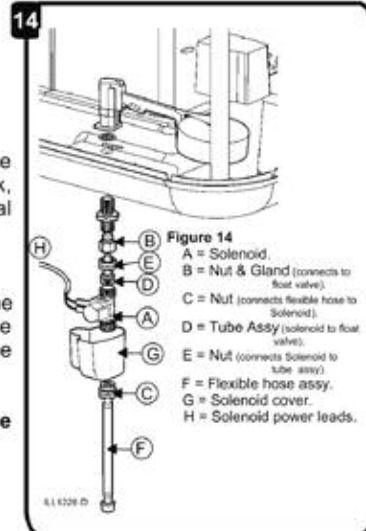

Figure 14
A = Solenoid.
B = Nut & Gland (connects to float valve).
C = Nut (connects flexible hose to Solenoid).
D = Tube Assy (solenoid to float valve).
E = Nut (connects Solenoid to tube Assy).
F = Flexible hose Assy.
G = Solenoid cover.
H = Solenoid power leads.

> Manual ICON EXH

Breezair®

Installing the EXH

7

LOCATING THE WALL/REMOTE CONTROLS

The wall control should be placed approximately 1.5 metres above the floor, in the most used room in the home. This will give the optimum temperature sensing and operating position for the user.

Placement is critical for correct functioning of the thermostat (incorporated in the wall control / remote control). The following points must be taken into consideration:

- Avoid direct sunlight exposure.
- Avoid mounting on external walls.
- Avoid mounting the wall control near heat sources such as stoves and televisions.
- Do not locate in the direct airflow of the duct outlets.
- Do not locate in strong drafts or in dead spots such as cupboards/drawers.
- Always fill in the cable entry hole. Hot air coming through the wall may interfere with the temperature measurement.

⚠ CAUTION! Always make sure there are no electrical cables, gas or water pipes, or the like, behind where you intend to drill.

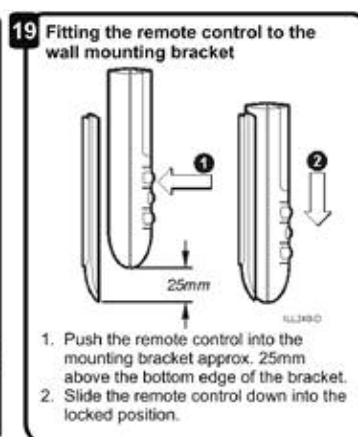
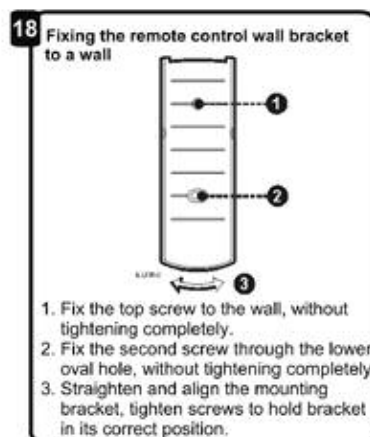
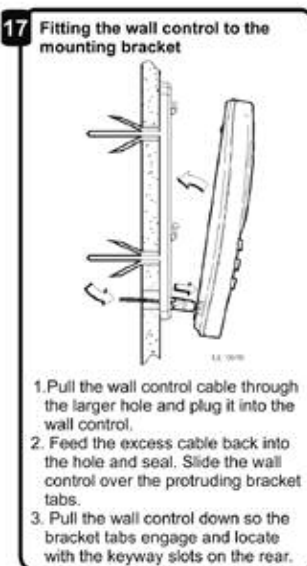
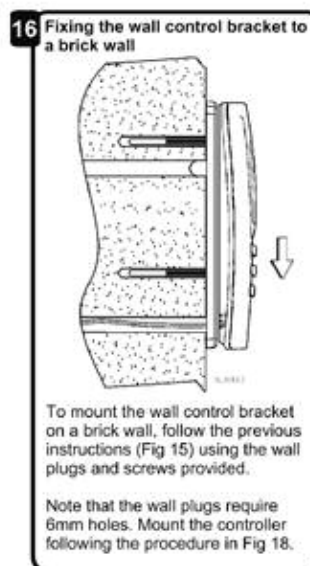
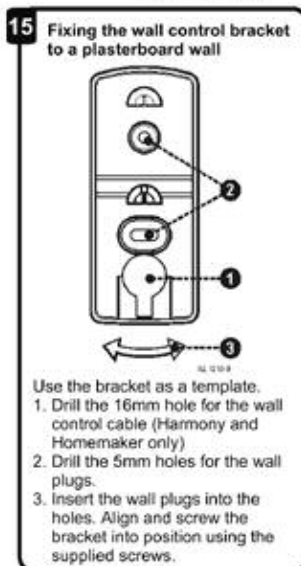

Running the wall control cable to the wall control

Using the loop on the end, draw the cable through the wall cavity to the hole made at the wall bracket. Carefully remove the tape from the cable loops and check that the plug has not been damaged. Connect the cable to the wall control and mount the wall control onto its bracket.

Important! Take care not to damage the cable or plug during this process. Always seal the cable entry hole.

> Manual ICON EXH

REMOTE RECEIVER (RF coolers only)

The receiver needs to be installed inside the cooler. Look for the receiver positioning sticker. It will be on the underside of the cabinet top, opposite the control box. See figure 20 for the large cabinet sticker location, and figure 21 for the small cabinet sticker location.

Drill a 2.5mm hole in the position shown on the sticker. Using the screw supplied, mount the receiver. Connect the receiver cable into the receiver (Fig 23), then connect the other end of the cable into the control box (Fig 8-J).

Important! Mount the receiver so that the plug and socket are facing away from the cooling pad. Ensure that the aerial is pointing in the direction shown (Fig 20).

Should there be signal receiving problems, the receiver may be installed outside the cooler in the roofspace, as outlined below.

Running the Receiver Cable outside the cooler (should there be signal problems).

The receiver should work correctly when installed inside the cooler as shown above. If not, and the receiver is installed and connected correctly, a 5 metre cable may be ordered from Seeley spare parts on 08 8276 3555. Part number: 830971.

Aim to secure the receiver away from the dropper and ductwork, but as near as possible to the location of the remote control.

For most installations, mounting the receiver as shown (Fig 22) will provide satisfactory performance.

For installations where the roof is framed with steel, resting the receiver between joists and keeping the antenna as far away as possible and perpendicular (at right angles) to joists will give the best results.

Note! Do not wrap any excess receiver cable around the receiver.

Important! The orientation and position of the receiver may affect the receiver's performance.

Other factors that may also influence performance are:

- (1).....Shielding from metal in the ceiling space lying between the receiver and Remote Control. This may include Sisalation / sarking (foil sheets), the dropper and ductwork.
- (2).....Reflections from metal around the receiver.
- (3).....Interference from nearby transmitters (e.g. mobile phone, AM radio, television, RF security systems, cordless phones, bluetooth components).

Other Options for Mounting Receiver

The standard installation arrangement will satisfy the majority of applications. However you may find difficult cases as discussed below:

(1)..... For signal problems in houses with a metal roof (Colourbond or similar), mount the receiver as close as possible to the metal roof with the antenna pointing directly away from the roof (Fig 25).

Flat Roof Installation

Where the installation is on a building with a flat roof and the ceiling cavity is less than 1.2 metres deep, alternative mounting locations may need to be found for the receiver. The options in order of preference are:

- (1)..... Install the receiver below the ceiling in the top of a nearby cupboard.
- (2)..... Install the receiver inside the cooler on the fan housing, making sure the antenna wire does not touch the pad. The receiver must be mounted on the opposite end of the fan housing to the motor.

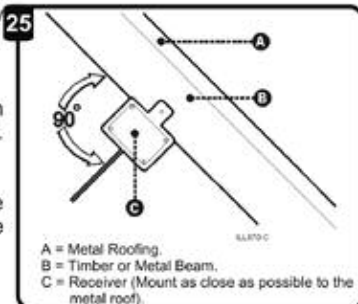
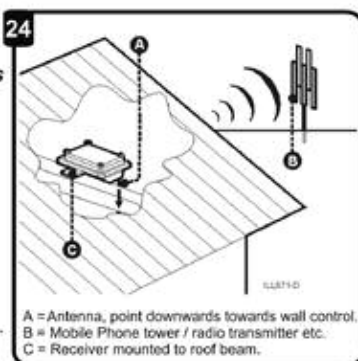
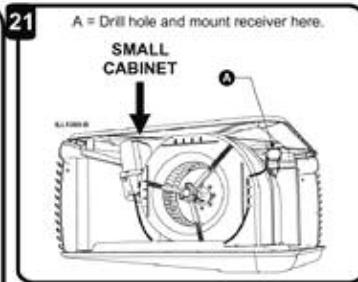
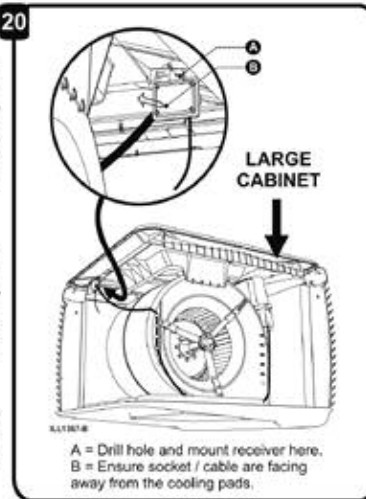

> Manual ICON EXH

HORIZON REMOTE CONTROL - SETTING THE ADDRESS CODE

The Breezair electronics module will automatically recognise the Horizon remote control connection, provided the address code has been correctly set.

This is simply achieved by fitting the batteries into the remote control **within 4 minutes of turning on the mains power at the electronics module**. The screen will flash "AUTO", the communication address code will take a few seconds to set, then the remote control can be turned on.

If communication cannot be achieved, the power to the Cooler will need to be turned off, and the batteries need to be removed from the remote control. Wait until the screen goes completely blank, then repeat the above procedure.

Horizon Remote Control - Location and testing

Important! One of the most critical parts of the installation is the location of the remote control and receiver. If these components are not set up or located correctly, it can result in chargeable service calls.

After the Cooler has been installed, place the remote control in the selected wall position and operate the cooler. Switch the cooler on and off 20 times at approximately 3 second intervals. 1 missed transmission in 20 is acceptable, 2 missed transmissions is not.

This procedure is done to check that the location you have chosen is not prone to interference or blocks the radio transmission. If the operation is intermittent, try another location. It may only need to be moved a few centimetres.



PREPARING TO COMMISSION USING THE WALL CONTROL

We recommend that you have a short test lead on hand for Coolers with a hard wired control system. You can then take the wall control to the roof and control the Cooler from there. This will save you a lot of time. The short test leads are available from your Seeley spare parts distributor (P/No - 831534).

Power up the cooler using the on / off switch on the Electronics Module. Test motor and pump operation. Look at the front of the Module where 2 light emitting diodes (LEDs) are situated (Fig 27 G & H). The top LED is "tricolour" and can glow green, red or amber. The bottom LED is red only. If the top LED (Fig 27, item G) is double flashing green, everything is ok, this is normal operation.

The following information allows quick diagnosis at start up -

1/The "Tricolour (top) LED" acts as a general diagnostic indicator, and will function as follows:

- **Green double flash every 2 seconds** indicates the control is running normally. If it does not glow at all, then there is either no power to the Electronics Module (check isolating switch, circuit breaker, plug and socket connection in the roof space), or a failure has occurred.

- **Amber for 1 second** (Horizon remote controls only) indicates that the Electronics Module has received a command at an incorrect ID address. (See the Horizon remote control - setting address code section above, to re establish the code)

- **Red flashing** indicates one or more of the following fault codes is present:

- 1 **Red Flash** indicates..... Fault Code #1 – Communication Failure.
- 2 **Red Flashes** indicates..... Fault Code #2 – Failure to Detect Water at Probes. (only for coolers fitted with Solenoid, Probes and Drain Valve).
- 4 **Red Flashes** indicates.... Fault Code #4 – Failure to Clear Probes during drain. (Only for coolers fitted with Solenoid, Probes and Drain Valve).
- 7 **Red Flashes** indicates.... Fault Code #7 - Incorrect Supply Frequency.

2/ The "Red (bottom) LED" indicates the status of the WaterManager measurement circuit and will function as follows:

- 1 **Flash** indicates..... WaterManager is operating and the measured salinity is below the set point.
- 2 **Flashes** indicates..... WaterManager is operating and the measured salinity is above the set point.
- 3 **Flashes** indicates..... The Salinity Control Method = Drain every 65 minutes.
- 4 **Flashes** indicates..... Incorrect Salinity Control Method selected.

Continuously On indicates: The probes are open circuit, or measured salinity is less than 20us/cm (the water is very pure, ie has very little salt content).

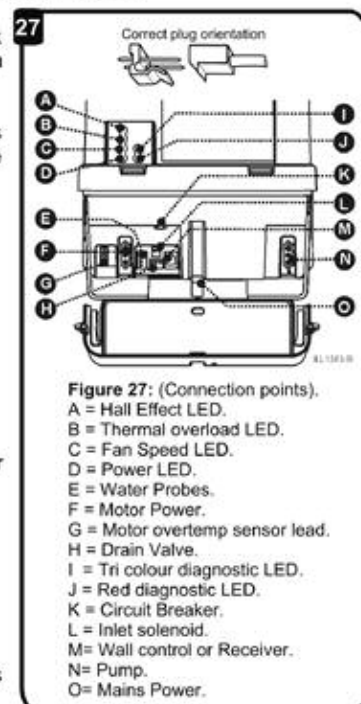

Figure 27: (Connection points).

- A = Hall Effect LED.
- B = Thermal overload LED.
- C = Fan Speed LED.
- D = Power LED.
- E = Water Probes.
- F = Motor Power.
- G = Motor overtemp sensor lead.
- H = Drain Valve.
- I = Tri colour diagnostic LED.
- J = Red diagnostic LED.
- K = Circuit Breaker.
- L = Inlet solenoid.
- M = Wall control or Receiver.
- N = Pump.
- O = Mains Power.

> Manual ICON EXH

Breezair®

Installing the EXH **10**

DIRECT DRIVE MOTOR

This Breezair cooler incorporates the revolutionary Seeley electronically commutated direct drive motor system.

No setup is required for this motor, it automatically adjusts to provide optimum performance for the installation.

This new direct drive system eliminates the need to adjust belts and pulleys. There is no need to set motor current and low speed.

Please familiarise yourself with the LED display (Fig 29), to ensure that the system is running as intended when you have installed the cooler.

Component location

All Breezair coolers are fitted with a main cooler control box (Fig 28 - A).

Note! The control box cover will only open and close with the ON / OFF switch in the "OFF" position. Do not try to force the cover open with the switch in the "ON" position.

Note! Take care to position the cables into the cover slots when closing, so that they do not become caught or pinched.

The direct drive motor (Fig 28 - B) is situated inside the fan scroll assembly (Fig 29 - C).

Electrical Connections

The motor and control box will arrive assembled and connected. All coolers are factory tested.

Refer to figure 27 for the correct connection points and corresponding components if necessary.

Note! The control box is a non - serviceable part. Do not open or attempt to repair any components.

TESTING THE DIRECT DRIVE SYSTEM

Turn the cooler on at the wall control, in "Ventilation" mode. The fan only will commence operation. Observe the LED readout on the top of the Direct Drive speed control box (Fig 29). LEDs 1 - 4 should be on (glowing green).

LED 1 when on (glows green), indicates the direct drive motor is rotating.

LED 2 when on (glows green), indicates the motor temperature sensor is working, and the motor is operating within its temperature range.

LED 3 when on (glows green), indicates the motor is rotating at the correct speed for the given wall control setting.

LED 4 when on (glows green) indicates mains power is applied to the motor when the ON button of the wall control has been pressed.

Important! Always turn "OFF" mains power to the cooler before checking connections or touching wiring and components.

If some or all of the LEDs are not glowing green, check the connections for the associated components.

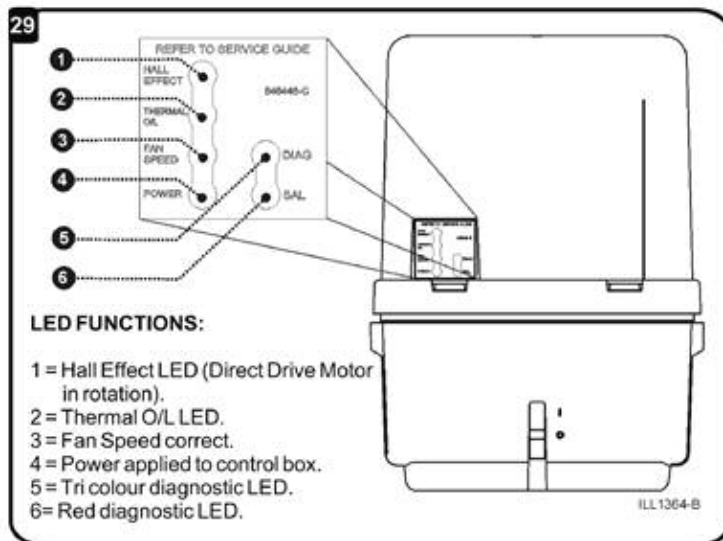
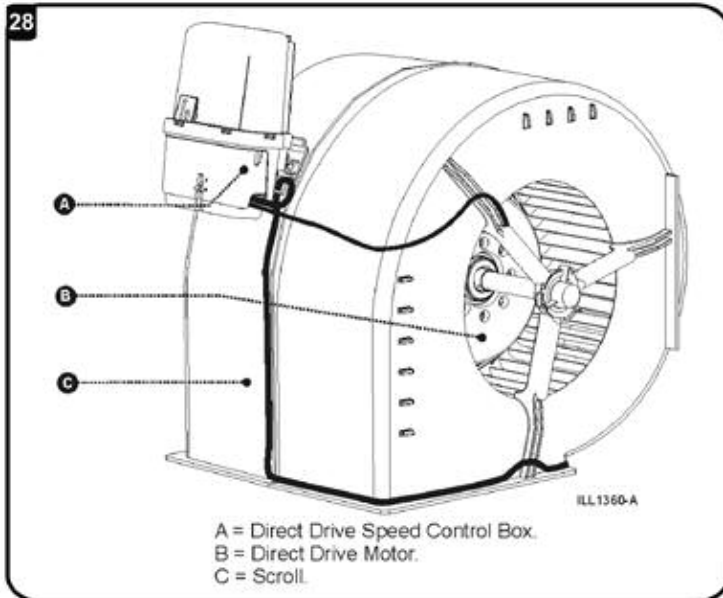

> Manual ICON EXH

Breezair®

Installing the EXH **11**

SETTING THE WATER LEVEL

Horizon and Harmony

Isolate power to the electronics module and disconnect the pump electrical plug, making sure the plug is kept away from any water. Turn the power back on.

Turn on the water supply. Turn the Cooler "ON", select "MANUAL" - "COOL" mode. Set the fan to speed "1". Allow the tank (reservoir) to fill with water. The float valve will eventually stop the water from entering the Cooler. Wait for this to happen and check the water level. The correct water level is shown in Fig 31.

If the level is too high rotate the float clockwise. Drain some water from the tank and allow it to refill to the new set point. If too low rotate the float in an anticlockwise direction (Fig 30).

Once the water level is correct, isolate the power, reconnect the pump plug to the electronics module, then restore the power to the Cooler.

Homemaker

Turn on the water supply. Allow the tank (reservoir) to fill with water. The float valve will eventually stop the water from entering the Cooler. Wait for this to happen and check the water level.

The correct water level is shown in Fig 31.

If the level is too high rotate the float clockwise. Drain some water from the tank and allow it to refill to the new set point. If too low rotate the float in an anticlockwise direction (Fig 30).

It is advisable to check the water level again after the float valve seal has "bedded in." After the unit has been sitting for a time with pressure on the float valve, drain and refill the tank. A small amount of movement in the float arm can make a difference in the amount of water in the tank.

Once the water level is correct, isolate the control box and reconnect the pump plug.

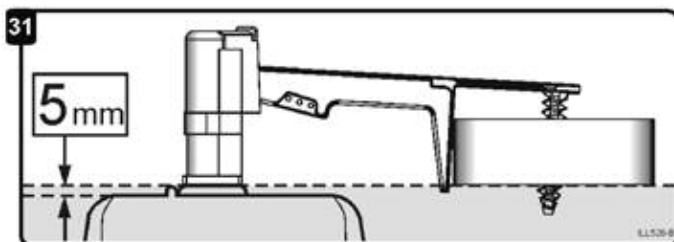
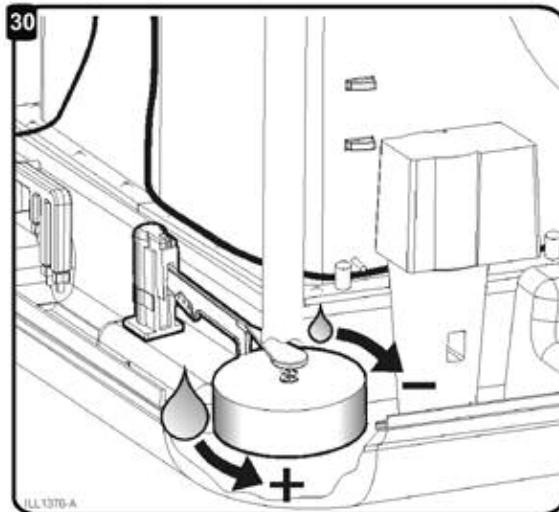

REFITTING THE PAD FRAMES

(For EXH210 units only) There are 90mm pads fitted to the front and rear, with 100mm pads fitted to the sides (facing the fan scroll holes). These pads must be refitted to their original positions, or the larger pads could catch on the float valve or components mounted on the scroll.

If fitted incorrectly, a drop in performance may be found, water can bypass the pad and be carried over into the airstream and ducting and/or damage to the pads or electronic components may occur.

The 100mm pads will be secured with BLUE retaining pins.

(For all unit sizes) To refit the pad frame, locate the bottom edge in the tank groove, then push the top in under the lid. The frame should clip into the Cooler with a firm push of the hand at the two points where the screwdriver was used.

Remember to insert the corner clips after replacing the pad frame(s) (Fig 32).

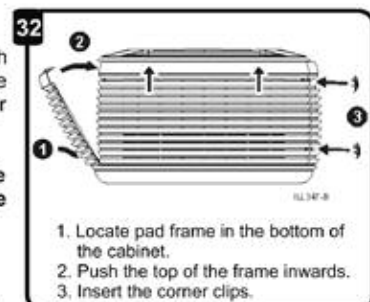

1. Locate pad frame in the bottom of the cabinet.
2. Push the top of the frame inwards.
3. Insert the corner clips.

> Manual ICON EXH

Breezair®

Installing the EXH

12

TESTING THE COOLER

Once you are satisfied that the Cooler is installed and commissioned correctly, it is important to run the cooler and ensure that everything is working as it should.

For Coolers with Horizon controls, try turning the Cooler on and off with the remote control in all of the rooms in the house. This will make sure that the receiver is located correctly.

Check that the unit runs quietly and with an even distribution of air to all outlets.

Make sure there are no water leaks. Initiate a drain of the tank by pressing the drain button (Horizon) or both the up and down buttons together (Harmony), with the wall control in the "OFF" state (Fig 33). Check the drain fittings and pipes, making sure there are no leaks.

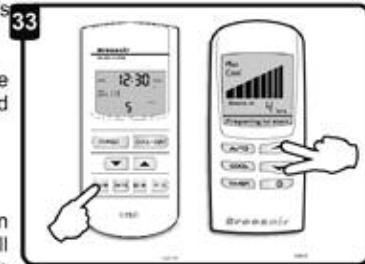

CLEAN UP THE SITE

Clean up and tidy the premises, removing all rubbish. Your aim should be to have the customer not even aware that you have been, apart from having their new Breezair installed to enjoy!



SHOW THE CUSTOMER THEIR NEW COOLER

This is a good time to explain the features and principles of Evaporative Ducted Cooling to the new Owner. Explain the wall control operation, how to exhaust the premises, and how to best run their Cooler.

Please take a few moments to explain to the customer the following:

- How far the windows need to be opened.
- How to turn the unit on.
- Explain the "Preparing to start" mode (Harmony & Homemaker only).
- How to operate the cooler "manually".
- How to operate the cooler in "vent" mode only.
- How to operate the cooler in "auto" mode.
- Explain the "ECONOMY" and "PRE-COOL" modes (Horizon only).
- How to drain the cooler.
- How to turn the power and water off.
- Maintenance requirements.

Present the customer with their warranty card for their attention.

Present the customer with their owners manual, and encourage them to keep it for future reference.



> Manual ICON EXH



For all your Breezair warranty and service needs, contact your local Breezair dealer direct.

842271-E

0704